



**DATE:** November 6, 2019  
**TO:** Tyler Schroeder, Director of Administrative Services  
**FROM:** Brad Bennett, AS Finance Manager  
**SUBJECT:** Approval to Purchase Replacement Dump Truck, Dump Body, Hook Lift Sander, and Plow

• **Background & Purpose**

Public Works Equipment Services is requesting approval to purchase a replacement dump truck, and miscellaneous components, including upgrading to a 4x4 (will provide better traction during inclement weather use), and to add a hook lift system (will allow truck to be used year-round, and not just for snow/ice control). These purchases will total \$281,677.87, and will be processed as two separate orders:

1. One 2021 Freightliner 108SD 4x4 Diesel Dump Truck will be purchased from vendor Freightliner Northwest, located in Olympia, using Washington State Contract #01513 (expires 06/13/2020). The total price for this dump truck is \$136,494.67, including sales tax.
2. One 2021 Dump Body, Hook Lift Sander, and Plow will be purchased from vendor Northend Truck Equipment, located in Marysville, using Washington State Contract #01117 (expires 05/01/2020). The total price for this purchase is \$145,183.20, including installation and sales tax.

• **Funding**

This planned replacement was included in the Exhibit B Capital List, and \$165,000.00 in funds were approved in the Equipment Rental & Revolving Fund budget approved on Ordinance #2018-064, as part of the 2019-2020 budget process. A budget modification was approved in September to transfer an additional \$100,000.00 funds. Public Works has adequate budget authority available for the additional \$16,677.87. I concur with this request.

  
AS Finance Manager

Approved as recommended:

\_\_\_\_\_  
Director of Administrative Services

Date of Council Action \_\_\_\_\_



Jon Hutchings

Director

## MEMORANDUM

**To:** Brad Bennett, AS Finance Manager  
**Through:** Jon Hutchings, Public Works Director  
**From:** Eric L. Schlehuber, PW Equipment Services Manager  
**Date:** November 6, 2019  
**Re:** Purchase of one (1) 2021 Freightliner 108SD 4X4 Diesel Dump Truck Cab and Chassis (State Contract #01513, Various Cab & Chassis)

- Requested Action**

After researching costs of pickup trucks, I am requesting Executive approval to purchase one (1) 2021 Freightliner 108SD 4X4 Diesel Dump Truck Cab and Chassis from the Washington State Bid Procurement List (Contract #01513, Various Cab and Chassis). The current state contract is for the period of June 13, 2019 through June 13, 2020. This 5YD Single Axle 4x4 Dump Truck will be used to replace the following unit:

DEPARTMENT	REPLACE UNIT	YEAR / MAKE / MODEL	EST. MILEAGE
M&O	213	1988 International 5 YD Single Axle Dump Truck	56,129

- Background and Purpose**

This unit was approved for replacement in the 2019-2020 Equipment Rental and Revolving Capital Equipment Budget to be used by Whatcom County Public Works. The truck bed and hook lift sander and plow (#456 and #596) are under a separate bid award request. The Maintenance and Operations Division will use this 5yd Single Axle 4x4 Dump Truck regularly in the performance of county business.

VENDOR	YEAR / MAKE / MODEL	QTY	PRICE EACH	SALES TAX TOTAL (8.2%)	EXTENDED TOTAL
Freightliner Northwest	2021 Freightliner 108SD 4X4 Diesel Dump Truck Cab and Chassis	1	\$126,150.34	\$10,344.33	\$136,494.67

- Funding Amount and Source**

This replacement was budgeted during the 2019-2020 budget process in the amount of \$165,000.00. To correct a budgeting error, an additional \$100,000 budget transfer was approved in 2019 to upgrade the vehicle to 4x4 and a hook lift bed, for a total of \$265,000 (10% allowance of \$291,500.00). I am requesting Executive approval to purchase this unit from Freightliner Northwest of Olympia, Washington for the price of \$126,150.34, plus 8.2% sales tax of \$10,344.33 for a total amount of \$136,494.67. A separate bid award request for the hook lift sander and plow is concurrently in process in the amount of \$145,183.20 bringing the total for both truck, truck bed and hook lift to \$281,677.87, which is within the 10% allowance.

- Recommended Action**

Please approve this purchase and forward to the Executive and County Council for approval at the November 19, 2019 County Council Meeting. Please contact Eric L. Schlehuber at extension 6405 if you have any questions or concerns.



GORDON TRUCK CENTERS DEALER FAMILY

November 5, 2019

**Whatcom County – Freightliner 108SD 4X4 Truck Chassis from WS DOT Contract**

**Segments A and B #01513 – Various Cab and Chassis**

<b><u>Base Price</u></b>	<b><u>\$84,474.97</u></b>
Allison 3000RDS 5-Speed w/Fixed Shift for Snow-Plow	INCL
Electric Trailer Brakes to Include 7-Way Plug @EOF (segment A item #33)	962.00
26K# Rear Suspension (4X4) Specification	INCL
14" Steel Painted Bumper	234.00
24" Front Frame Extension	INCL
Power Windows & Door Locks	204.00
Sun Visor for Safety	156.00
70-Gallon LH Rectangular Fuel Tank	107.00
Side of Hood Air Intake w/Snow Door	653.00
(5) Spare Rocker Switches in Dash	113.00
Interior Package for CB Radio Provisions	233.00
Battery Disconnect Switch	156.00
2-Valve Parking Valve w/Auto Neutral for Allison	129.00
16K# Detroit Steer Axle	INCL
16K# Taper Leaf Suspension	INCL
Standard Drum Brakes w/4X4 Option	INCL
Battery Jump Studs Next to Starter	89.00
Snow Plow Headlight Wiring/Switch (segment B page 61 Item#21)	168.00
PTO Switch w/Disengage Set to 25MPH (segment B page 78 item #50)	111.00
315 Michelin Steer Axle Tires	INCL
16K 4X4 Pkg. Including Tires, Springs, Brakes, Transfer Case (per email 8/17/17)	36,269.00



GORDON TRUCK CENTERS DEALER FAMILY

<b>OFF CONTRACT AS PER WHATCOM COUNTY SPEC</b>		<b>MSRP</b>
Horton 2-Speed Fan	274.55	(323.00)
LED Marker Lights	28.90	(34.00)
Dual Heated Mirrors w/RH & LH Remote	243.10	(286.00)
Premium High Back Driver Seat	351.90	(414.00)
Brake Application Gauge	56.95	(67.00)
Dash Mounted Air Restriction Gauge	34.00	(40.00)
Cobra 29 CB Radio Installed	140.25	(165.00)
Pre-Trip Light Check Switch	10.20	(12.00)
<b>Sub-Total Less WA Admin Fee</b>	<b>\$125,198.82</b>	
<b>Enterprise Services Fee .0076%</b>	<b>951.52</b>	
<b>Sub-Total w/DES Fee</b>	<b>\$126,150.34</b>	
<b>WA Sales Tax Thurston County @8.2%</b>	<b>\$10,344.33</b>	
<b>Grand Sale Price w/All Taxes and Fees</b>	<b>\$136,494.67</b>	

Please accept this pricing and following specification pages for the proposed sale of (1) 2021MY Freightliner 108SD 4X4 as priced per the WS DOT Contract 01513. The "off contract" items have been changed to reflect the 15% discount and certain items from Segment B of the State contract have been noted for clarification.

Paul M. Buckel

Freightliner Northwest

**Prepared for:**  
Justin Myers  
WHATCOM COUNTY PUBLIC  
WORKS  
901 W SMITH RD

BELLINGHAM, WA 98226  
Phone: 360 815 5596

**Prepared by:**  
Paul Buckel  
FREIGHTLINER NORTHWEST  
13232 CASE ROAD S.W.  
OLYMPIA, WA 98512  
Phone: 206-601-5117

*A proposal for*  
**WHATCOM COUNTY PUBLIC WORKS**

*Prepared by*  
**FREIGHTLINER NORTHWEST**  
*Paul Buckel*

*Nov 01, 2019*

**Freightliner 108SD**



Components shown may not reflect all spec'd options and are not to scale



Prepared for:  
Justin Myers  
WHATCOM COUNTY PUBLIC  
WORKS  
901 W SMITH RD

BELLINGHAM, WA 98226  
Phone: 360 815 5596

Prepared by:  
Paul Buckel  
FREIGHTLINER NORTHWEST  
13232 CASE ROAD S.W.  
OLYMPIA, WA 98512  
Phone: 206-601-5117

## S P E C I F I C A T I O N   P R O P O S A L

Description
<b>Price Level</b>
SD PRL-20D (EFF:04/30/19)
<b>Data Version</b>
SPECPRO21 DATA RELEASE VER 024
<b>Vehicle Configuration</b>
108SD CONVENTIONAL CHASSIS <b>2021 MODEL YEAR SPECIFIED</b> SET BACK AXLE - TRUCK TRAILER TOWING PROVISION AT END OF FRAME FOR TRUCK LH PRIMARY STEERING LOCATION
<b>General Service</b>
TRUCK/TRAILER CONFIGURATION DOMICILED, USA (EXCLUDING CALIFORNIA AND CARB OPT-IN STATES) UTILITY/REPAIR/MAINTENANCE SERVICE GOVERNMENT BUSINESS SEGMENT DIRT/SAND/ROCK COMMODITY TERRAIN/DUTY: 100% (ALL) OF THE TIME, IN TRANSIT, IS SPENT ON PAVED ROADS MAXIMUM 8% EXPECTED GRADE ROUGH, MAINTAINED, CONCRETE OR ASPHALT PAVEMENT - MOST SEVERE IN-TRANSIT (BETWEEN SITES) ROAD SURFACE FREIGHTLINER SD VOCATIONAL WARRANTY EXPECTED FRONT AXLE(S) LOAD : 16000.0 lbs EXPECTED REAR DRIVE AXLE(S) LOAD : 22620.0 lbs EXPECTED GROSS VEHICLE WEIGHT CAPACITY : 38620.0 lbs EXPECTED GROSS COMBINATION WEIGHT : 80000.0 lbs



Prepared for:  
Justin Myers  
WHATCOM COUNTY PUBLIC  
WORKS  
901 W SMITH RD

BELLINGHAM, WA 98226  
Phone: 360 815 5596

Prepared by:  
Paul Buckel  
FREIGHTLINER NORTHWEST  
13232 CASE ROAD S.W.  
OLYMPIA, WA 98512  
Phone: 206-601-5117

Description
<b>Truck Service</b>
ROLL OFF/ROLL ON BODY EXPECTED TRUCK BODY LENGTH : 0.0 ft NORTHEND TRUCK EQUIPMENT, INC.
<b>Tractor Service</b>
FLATBED TRAILER SINGLE (1) TRAILER
<b>Engine</b>
CUM L9 270 HP @ 2000 RPM; 2200 GOV RPM, 800 LB/FT @ 1300 RPM
<b>Electronic Parameters</b>
65 MPH ROAD SPEED LIMIT CRUISE CONTROL SPEED LIMIT SAME AS ROAD SPEED LIMIT PTO RPM WITH CRUISE SET SWITCH - 700 RPM PTO RPM WITH CRUISE RESUME SWITCH - 800 RPM PTO MODE CANCEL VEHICLE SPEED - 25 MPH PTO GOVERNOR RAMP RATE - 100 RPM PER SECOND FUEL DOSING OF AFTERTREATMENT ENABLED IN PTO MODE-CLEANS HYDROCARBONS AT HIGH TEMPERATURES ONLY ENGINE BRAKE WITH CRUISE CONTROL ENABLED AT 3 MPH ABOVE SET SPEED, 2 MPH INCREMENT BETWEEN BRAKING LEVELS PTO MINIMUM RPM - 700 REGEN INHIBIT SPEED THRESHOLD - 5 MPH
<b>Engine Equipment</b>
2016-2019 ONBOARD DIAGNOSTICS/2010 EPA/CARB/FINAL GHG17 CONFIGURATION NO 2008 CARB EMISSION CERTIFICATION STANDARD OIL PAN ENGINE MOUNTED OIL CHECK AND FILL SIDE OF HOOD AIR INTAKE WITH FIREWALL MOUNTED DONALDSON AIR CLEANER DR 12V 160 AMP 28-SI QUADRAMOUNT PAD ALTERNATOR WITH REMOTE BATTERY VOLT SENSE



**Prepared for:**  
Justin Myers  
WHATCOM COUNTY PUBLIC  
WORKS  
901 W SMITH RD

BELLINGHAM, WA 98226  
Phone: 360 815 5596

**Prepared by:**  
Paul Buckel  
FREIGHTLINER NORTHWEST  
13232 CASE ROAD S.W.  
OLYMPIA, WA 98512  
Phone: 206-601-5117

---

**Description**

(2) DTNA GENUINE, FLOODED STARTING, MIN  
2000CCA, 370RC, THREADED STUD BATTERIES  
BATTERY BOX FRAME MOUNTED  
STANDARD BATTERY JUMPERS  
SINGLE BATTERY BOX FRAME MOUNTED LH  
SIDE UNDER CAB  
WIRE GROUND RETURN FOR BATTERY CABLES  
WITH ADDITIONAL FRAME GROUND RETURN  
NON-POLISHED BATTERY BOX COVER  
CAB AUXILIARY POWER CABLE  
POSITIVE LOAD DISCONNECT WITH CAB  
MOUNTED CONTROL SWITCH MOUNTED  
OUTBOARD DRIVER SEAT  
POSITIVE AND NEGATIVE POSTS FOR  
JUMPSTART LOCATED ON FRAME NEXT TO  
STARTER  
CUMMINS TURBOCHARGED 18.7 CFM AIR  
COMPRESSOR WITH INTERNAL SAFETY VALVE  
ELECTRONIC ENGINE INTEGRAL SHUTDOWN  
PROTECTION SYSTEM  
CUMMINS EXHAUST BRAKE INTEGRAL WITH  
VARIABLE GEOMETRY TURBO WITH ON/OFF  
DASH SWITCH, ACTIVATES STOP LAMPS  
RH OUTBOARD UNDER STEP MOUNTED  
HORIZONTAL AFTERTREATMENT SYSTEM  
ASSEMBLY WITH RH B-PILLAR MOUNTED  
VERTICAL TAILPIPE  
ENGINE AFTERTREATMENT DEVICE,  
AUTOMATIC OVER THE ROAD REGENERATION  
AND DASH MOUNTED REGENERATION  
REQUEST SWITCH  
10 FOOT 06 INCH (126 INCH+0/-5.9 INCH)  
EXHAUST SYSTEM HEIGHT  
RH CURVED VERTICAL TAILPIPE B-PILLAR  
MOUNTED ROUTED FROM STEP  
13 GALLON DIESEL EXHAUST FLUID TANK  
100 PERCENT DIESEL EXHAUST FLUID FILL  
STANDARD DIESEL EXHAUST FLUID PUMP  
MOUNTING  
LH MEDIUM DUTY STANDARD DIESEL EXHAUST  
FLUID TANK LOCATION  
STANDARD DIESEL EXHAUST FLUID TANK CAP  
ALUMINUM AFTERTREATMENT  
DEVICE/MUFFLER/TAILPIPE SHIELD(S)





**Prepared for:**  
Justin Myers  
WHATCOM COUNTY PUBLIC  
WORKS  
901 W SMITH RD

BELLINGHAM, WA 98226  
Phone: 360 815 5596

**Prepared by:**  
Paul Buckel  
FREIGHTLINER NORTHWEST  
13232 CASE ROAD S.W.  
OLYMPIA, WA 98512  
Phone: 206-601-5117

#### Description

HORTON 2-SPEED DRIVEMASTER ADVANTAGE  
POLAREXTREME FAN DRIVE  
  
AUTOMATIC FAN CONTROL WITH DASH  
SWITCH AND INDICATOR LIGHT, NON ENGINE  
MOUNTED  
  
CUMMINS SPIN ON FUEL FILTER  
  
COMBINATION FULL FLOW/BYPASS OIL FILTER  
  
1115 SQUARE INCH ALUMINUM RADIATOR  
  
ANTIFREEZE TO -34F, OAT (NITRITE AND  
SILICATE FREE) EXTENDED LIFE COOLANT  
  
GATES BLUE STRIPE COOLANT HOSES OR  
EQUIVALENT  
  
CONSTANT TENSION HOSE CLAMPS FOR  
COOLANT HOSES  
  
RADIATOR DRAIN VALVE  
  
PHILLIPS-TEMRO 1000 WATT/115 VOLT BLOCK  
HEATER  
  
CHROME ENGINE HEATER RECEPTACLE  
MOUNTED UNDER LH DOOR  
  
ELECTRIC GRID AIR INTAKE WARMER  
  
DELCO 12V 38MT HD STARTER WITH  
INTEGRATED MAGNETIC SWITCH

#### Transmission

ALLISON 3000 RDS AUTOMATIC TRANSMISSION  
WITH PTO PROVISION

#### Transmission Equipment

ALLISON VOCATIONAL PACKAGE 223 -  
AVAILABLE ON 3000/4000 PRODUCT FAMILIES  
WITH VOCATIONAL MODELS RDS, HS, MH AND  
TRV  
  
ALLISON VOCATIONAL RATING FOR ON/OFF  
HIGHWAY APPLICATIONS AVAILABLE WITH ALL  
PRODUCT FAMILIES  
  
PRIMARY MODE GEARS, LOWEST GEAR 1,  
START GEAR 1, HIGHEST GEAR 5, AVAILABLE  
FOR 3000/4000 PRODUCT FAMILIES ONLY  
  
SECONDARY MODE GEARS, LOWEST GEAR 1,  
START GEAR 1, HIGHEST GEAR 4, AVAILABLE  
FOR 3000/4000 PRODUCT FAMILIES ONLY  
  
PRIMARY SHIFT SCHEDULE RECOMMENDED BY  
DTNA AND ALLISON, THIS DEFINED BY ENGINE  
AND VOCATIONAL USAGE

**Prepared for:**  
Justin Myers  
WHATCOM COUNTY PUBLIC  
WORKS  
901 W SMITH RD

BELLINGHAM, WA 98226  
Phone: 360 815 5596

**Prepared by:**  
Paul Buckel  
FREIGHTLINER NORTHWEST  
13232 CASE ROAD S.W.  
OLYMPIA, WA 98512  
Phone: 206-601-5117

---

**Description**

SECONDARY SHIFT SCHEDULE  
RECOMMENDED BY DTNA AND ALLISON, THIS  
DEFINED BY ENGINE AND VOCATIONAL USAGE

PRIMARY SHIFT SPEED RECOMMENDED BY  
DTNA AND ALLISON, THIS DEFINED BY ENGINE  
AND VOCATIONAL USAGE

SECONDARY SHIFT SPEED RECOMMENDED BY  
DTNA AND ALLISON, THIS DEFINED BY ENGINE  
AND VOCATIONAL USAGE

FUEL SENSE 2.0 DISABLED - PERFORMANCE -  
TABLE BASED

DRIVER SWITCH INPUT - DEFAULT - NO  
SWITCHES

ELECTRONIC TRANSMISSION CUSTOMER  
ACCESS CONNECTOR MOUNTED BACK OF CAB

CUSTOMER INSTALLED CHELSEA 280 SERIES  
PTO

PTO MOUNTING, LH SIDE OF MAIN  
TRANSMISSION

MAGNETIC PLUGS, ENGINE DRAIN,  
TRANSMISSION DRAIN, AXLE(S) FILL AND  
DRAIN

PUSH BUTTON ELECTRONIC SHIFT CONTROL,  
DASH MOUNTED

TRANSMISSION PROGNOSTICS - ENABLED 2013

WATER TO OIL TRANSMISSION COOLER, IN  
RADIATOR END TANK

MERITOR MTC-4210 AND MTC-4213 TRANSFER  
CASE OIL COOLER

TRANSMISSION OIL CHECK AND FILL WITH  
ELECTRONIC OIL LEVEL CHECK

MERITOR MTC 4210XL-EVO 2-SPEED  
TRANSFER CASE

TRANSFER CASE SHIFT CONTROLS WITH  
TRANSFER CASE PTO ON/OFF SWITCH WHEN  
APPLICABLE

SYNTHETIC TRANSMISSION FLUID (TES-295  
COMPLIANT)

**Front Axle and Equipment**

MX-16-120 16,000# 1790MM KPI SINGLE FRONT  
DRIVE AXLE

4.56 FRONT AXLE RATIO

MXL 16T MERITOR EXTENDED LUBE FRONT  
STEERING AXLE DRIVELINE WITH HALF ROUND  
YOKES



**Prepared for:**  
Justin Myers  
WHATCOM COUNTY PUBLIC  
WORKS  
901 W SMITH RD

BELLINGHAM, WA 98226  
Phone: 360 815 5596

**Prepared by:**  
Paul Buckel  
FREIGHTLINER NORTHWEST  
13232 CASE ROAD S.W.  
OLYMPIA, WA 98512  
Phone: 206-601-5117

---

**Description**

---

MERITOR 16.5X6 Q+ MX DRIVE AXLE CAST  
SPIDER CAM FRONT BRAKES  
NON-ASBESTOS FRONT BRAKE LINING  
MERITOR CAST IRON FRONT BRAKE DRUMS  
FRONT BRAKE DUST SHIELDS  
FRONT GREASE SEAL  
STANDARD SPINDLE NUTS FOR ALL AXLES  
MERITOR AUTOMATIC FRONT SLACK  
ADJUSTERS  
STANDARD KING PIN BUSHINGS  
TRW TAS-85 POWER STEERING  
POWER STEERING PUMP  
4 QUART POWER STEERING RESERVOIR  
OIL/AIR POWER STEERING COOLER  
SYNTHETIC 75W-90 FRONT AXLE LUBE

**Front Suspension**

16,000# TAPERLEAF FRONT SUSPENSION  
MAINTENANCE FREE RUBBER BUSHINGS -  
FRONT SUSPENSION  
NO FRONT SUSPENSION OPTIONS  
FRONT SHOCK ABSORBERS

**Rear Axle and Equipment**

RS-23-161 23,000# R-SERIES SINGLE REAR  
AXLE  
4.56 REAR AXLE RATIO  
IRON REAR AXLE CARRIER WITH STANDARD  
AXLE HOUSING  
MXL 17T MERITOR EXTENDED LUBE MAIN  
DRIVELINE WITH HALF ROUND YOKES  
MXL 17T MERITOR EXTENDED LUBE  
INTERTRANSMISSION DRIVELINE WITH HALF  
ROUND YOKES  
MERITOR 16.5X7 Q+ CAST SPIDER CAM REAR  
BRAKES, DOUBLE ANCHOR, FABRICATED  
SHOES  
NON-ASBESTOS REAR BRAKE LINING  
BRAKE CAMS AND CHAMBERS ON REAR SIDE  
OF DRIVE AXLE(S)  
CAST IRON OUTBOARD REAR BRAKE DRUMS  
REAR OIL SEALS



**Prepared for:**  
Justin Myers  
WHATCOM COUNTY PUBLIC  
WORKS  
901 W SMITH RD

BELLINGHAM, WA 98226  
Phone: 360 815 5596

**Prepared by:**  
Paul Buckel  
FREIGHTLINER NORTHWEST  
13232 CASE ROAD S.W.  
OLYMPIA, WA 98512  
Phone: 206-601-5117

---

**Description**

---

WABCO TRISTOP D LONGSTROKE 1-DRIVE  
AXLE SPRING PARKING CHAMBERS  
HALDEX AUTOMATIC REAR SLACK ADJUSTERS  
ORGANIC SAE 80/90 REAR AXLE LUBE  
STANDARD REAR AXLE BREATHER(S)

**Rear Suspension**

26,000# FLAT LEAF SPRING REAR SUSPENSION  
WITH HELPER AND RADIUS ROD  
SPRING SUSPENSION - NO AXLE SPACERS  
STANDARD AXLE SEATS IN AXLE CLAMP  
GROUP  
FORE/AFT CONTROL RODS

**Brake System**

WABCO 4S/4M ABS  
REINFORCED NYLON, FABRIC BRAID AND WIRE  
BRAID CHASSIS AIR LINES  
FIBER BRAID PARKING BRAKE HOSE  
STANDARD BRAKE SYSTEM VALVES  
STANDARD AIR SYSTEM PRESSURE  
PROTECTION SYSTEM  
STD U.S. FRONT BRAKE VALVE  
RELAY VALVE WITH 5-8 PSI CRACK PRESSURE,  
NO REAR PROPORTIONING VALVE  
WABCO SYSTEM SAVER HP WITH INTEGRAL  
AIR GOVERNOR AND HEATER  
AIR DRYER MOUNTED OUTBOARD ON RH RAIL  
STEEL AIR BRAKE RESERVOIRS  
CLEAR FRAME RAIL FROM BACK OF CAB TO  
FRONT REAR SUSPENSION BRACKET LH RAIL  
INSIDE/OUTBOARD AND BELOW  
PULL CABLE ON WET TANK, PETCOCK DRAIN  
VALVES ON ALL OTHER AIR TANKS

**Trailer Connections**

AIR CONNECTIONS TO END OF FRAME WITH  
GLAD HANDS FOR TRUCK AND NO DUST  
COVERS  
PRIMARY CONNECTOR/RECEPTACLE WIRED  
FOR COMBINATION STOP/TURN, CENTER PIN  
POWERED THROUGH IGNITION WITH STOP  
SIGNAL PREWIRE PACKAGE  
SAE J560 7-WAY PRIMARY TRAILER CABLE  
RECEPTACLE MOUNTED END OF FRAME

Prepared for:  
Justin Myers  
WHATCOM COUNTY PUBLIC  
WORKS  
901 W SMITH RD

BELLINGHAM, WA 98226  
Phone: 360 815 5596

Prepared by:  
Paul Buckel  
FREIGHTLINER NORTHWEST  
13232 CASE ROAD S.W.  
OLYMPIA, WA 98512  
Phone: 206-601-5117

**Description**

UPGRADED CHASSIS MULTIPLEXING UNIT

**Wheelbase & Frame**

4850MM (191 INCH) WHEELBASE  
7/16X3-9/16X11-1/8 INCH STEEL FRAME  
(11.11MMX282.6MM/0.437X11.13 INCH) 120KSI  
1/4 INCH (6.35MM) C-CHANNEL INNER FRAME  
REINFORCEMENT  
1900MM (75 INCH) REAR FRAME OVERHANG  
FRAME OVERHANG RANGE: 71 INCH TO 80  
INCH  
24 INCH INTEGRAL FRONT FRAME EXTENSION  
CALC'D BACK OF CAB TO REAR SUSP C/L (CA) :  
125.39 in  
CALCULATED EFFECTIVE BACK OF CAB TO  
REAR SUSPENSION C/L (CA) : 120.89 in  
CALC'D FRAME LENGTH - OVERALL : 330.9  
CALCULATED FRAME SPACE LH SIDE : 57.13 in  
CALCULATED FRAME SPACE RH SIDE : 183.92  
in  
CALC'D SPACE AVAILABLE FOR DECKPLATE :  
125.45 in  
SQUARE END OF FRAME  
FRONT CLOSING CROSSMEMBER  
LIGHTWEIGHT HEAVY DUTY ALUMINUM ENGINE  
CROSSMEMBER  
STANDARD MIDSHIP #1 CROSSMEMBER(S)  
STANDARD REARMOST CROSSMEMBER  
STANDARD SUSPENSION CROSSMEMBER

**Chassis Equipment**

14 INCH PAINTED STEEL BUMPER  
FRONT TOW HOOKS - FRAME MOUNTED  
BUMPER MOUNTING FOR SINGLE LICENSE  
PLATE  
GRADE 8 THREADED HEX HEADED FRAME  
FASTENERS

**Fuel Tanks**

70 GALLON/264 LITER ALUMINUM FUEL TANK -  
LH  
25 INCH DIAMETER FUEL TANK(S)



Prepared for:  
Justin Myers  
WHATCOM COUNTY PUBLIC  
WORKS  
901 W SMITH RD

BELLINGHAM, WA 98226  
Phone: 360 815 5596

Prepared by:  
Paul Buckel  
FREIGHTLINER NORTHWEST  
13232 CASE ROAD S.W.  
OLYMPIA, WA 98512  
Phone: 206-601-5117

#### Description

PLAIN ALUMINUM/PAINTED STEEL  
FUEL/HYDRAULIC TANK(S) WITH PAINTED  
BANDS  
FUEL TANK(S) FORWARD  
PLAIN STEP FINISH  
FUEL TANK CAP(S)  
DAVCO 245 FUEL/WATER SEPARATOR WITH 12  
VOLT HEAT AND WATER IN FUEL SENSOR  
EQUIFLO INBOARD FUEL SYSTEM  
NO NATURAL GAS VEHICLE FUEL TANK VENT  
LINE/STACK  
HIGH TEMPERATURE REINFORCED NYLON  
FUEL LINE

#### Tires

MICHELIN XZU-S2 315/80R22.5 20 PLY RADIAL  
FRONT TIRES  
MICHELIN X WORKS XDY 11R22.5 16 PLY  
RADIAL REAR TIRES

#### Hubs

MERITOR IRON FRONT HUBS  
CONMET PRESET PLUS PREMIUM IRON REAR  
HUBS

#### Wheels

ACCURIDE 29300 22.5X9.00 10-HUB PILOT 6.38  
INSET 5-HAND STEEL DISC FRONT WHEELS  
ACCURIDE 28828 22.5X8.25 10-HUB PILOT 2-  
HAND HD STEEL DISC REAR WHEELS  
NO FRONT HUB COVERS

#### Cab Exterior

108 INCH BBC FLAT ROOF ALUMINUM  
CONVENTIONAL CAB  
AIR CAB MOUNTING  
NONREMOVABLE BUGSCREEN MOUNTED  
BEHIND GRILLE  
FRONT FENDERS SET-BACK AXLE  
LH AND RH GRAB HANDLES  
BRIGHT FINISH RADIATOR SHELL/HOOD BEZEL  
STATIONARY BLACK GRILLE WITH BRIGHT  
ACCENTS  
CHROME HOOD MOUNTED AIR INTAKE GRILLE  
FIBERGLASS HOOD



**Prepared for:**  
Justin Myers  
WHATCOM COUNTY PUBLIC  
WORKS  
901 W SMITH RD

BELLINGHAM, WA 98226  
Phone: 360 815 5596

**Prepared by:**  
Paul Buckel  
FREIGHTLINER NORTHWEST  
13232 CASE ROAD S.W.  
OLYMPIA, WA 98512  
Phone: 206-601-5117

---

**Description**

---

HOOD LINER INSULATION WITH SINGLE  
FIREWALL INSULATION  
SINGLE 14 INCH ROUND HADLEY AIR HORN  
UNDER LH DECK  
SINGLE ELECTRIC HORN  
SINGLE HORN SHIELD  
ALL UNIT(S) KEYED ALIKE WITH CUSTOMER  
SPECIFIED KEY NUMBER FT1013  
REAR LICENSE PLATE MOUNT END OF FRAME  
HALOGEN COMPOSITE HEADLAMPS WITH  
BRIGHT BEZELS  
LED AERODYNAMIC MARKER LIGHTS  
INTEGRAL STOP/TAIL/BACKUP LIGHTS  
STANDARD FRONT TURN SIGNAL LAMPS  
NO WORK LIGHT  
DUAL WEST COAST BRIGHT FINISH HEATED  
MIRRORS WITH LH AND RH REMOTE  
DOOR MOUNTED MIRRORS  
102 INCH EQUIPMENT WIDTH  
LH AND RH 8 INCH BRIGHT FINISH CONVEX  
MIRRORS MOUNTED UNDER PRIMARY  
MIRRORS  
RH DOWN VIEW MIRROR  
STANDARD SIDE/REAR REFLECTORS  
ELECTRIC HORN WARNING SYSTEM FOR PARK  
BRAKE NOT SET WITH DOOR OPEN AND ALL  
IGNITION KEY POSITIONS  
COMPOSITE EXTERIOR SUN VISOR  
63X14 INCH TINTED REAR WINDOW  
TINTED DOOR GLASS LH AND RH WITH TINTED  
NON-OPERATING WING WINDOWS  
RH AND LH ELECTRIC POWERED WINDOWS,  
PASSENGER SWITCHES ON DOOR(S)  
TINTED WINDSHIELD  
8 LITER WINDSHIELD WASHER RESERVOIR,  
CAB MOUNTED, WITHOUT FLUID LEVEL  
INDICATOR

**Cab Interior**

OPAL GRAY VINYL INTERIOR  
MOLDED PLASTIC DOOR PANEL WITHOUT  
VINYL INSERT WITH ALUMINUM KICKPLATE  
LOWER DOOR



**Prepared for:**  
Justin Myers  
WHATCOM COUNTY PUBLIC  
WORKS  
901 W SMITH RD

BELLINGHAM, WA 98226  
Phone: 360 815 5596

**Prepared by:**  
Paul Buckel  
FREIGHTLINER NORTHWEST  
13232 CASE ROAD S.W.  
OLYMPIA, WA 98512  
Phone: 206-601-5117

---

**Description**

MOLDED PLASTIC DOOR PANEL WITHOUT  
VINYL INSERT WITH ALUMINUM KICKPLATE  
LOWER DOOR

BLACK MATS WITH SINGLE INSULATION

NO DASH MOUNTED ASH TRAYS AND LIGHTER

FORWARD ROOF MOUNTED CONSOLE WITH  
UPPER STORAGE COMPARTMENTS WITHOUT  
NETTING

IN DASH STORAGE BIN

(2) CUP HOLDERS LH AND RH DASH

GRAY/CHARCOAL FLAT DASH

SMART SWITCH EXPANSION MODULE

HEATER, DEFROSTER AND AIR CONDITIONER

STANDARD HVAC DUCTING

MAIN HVAC CONTROLS WITH RECIRCULATION  
SWITCH

STANDARD HEATER PLUMBING

VALEO HEAVY DUTY A/C REFRIGERANT  
COMPRESSOR

BINARY CONTROL, R-134A

PREMIUM INSULATION

SOLID-STATE CIRCUIT PROTECTION AND  
FUSES

12V NEGATIVE GROUND ELECTRICAL SYSTEM

DOMED DOOR ACTIVATED LH AND RH, DUAL  
READING LIGHTS, FORWARD CAB ROOF

LH AND RH ELECTRIC DOOR LOCKS

(1) 12 VOLT POWER SUPPLY IN DASH

PREMIUM HIGH BACK AIR SUSPENSION DRIVER  
SEAT WITH 3 CHAMBER AIR LUMBAR,  
INTEGRATED CUSHION EXTENSION, FORWARD  
AND REAR CUSHION TILT, ADJUSTABLE SHOCK  
ABSORBER

BASIC HIGH BACK AIR SUSPENSION  
PASSENGER SEAT WITH MECHANICAL LUMBAR  
AND INTEGRATED CUSHION EXTENSION

DUAL DRIVER SEAT ARMRESTS, NO  
PASSENGER SEAT ARMRESTS

LH AND RH INTEGRAL DOOR PANEL ARMRESTS

VINYL WITH VINYL INSERT DRIVER SEAT

VINYL WITH VINYL INSERT PASSENGER SEAT

BLACK SEAT BELTS





**Prepared for:**  
Justin Myers  
WHATCOM COUNTY PUBLIC  
WORKS  
901 W SMITH RD

BELLINGHAM, WA 98226  
Phone: 360 815 5596

**Prepared by:**  
Paul Buckel  
FREIGHTLINER NORTHWEST  
13232 CASE ROAD S.W.  
OLYMPIA, WA 98512  
Phone: 206-601-5117

---

**Description**

ADJUSTABLE TILT AND TELESCOPING  
STEERING COLUMN  
4-SPOKE 18 INCH (450MM) STEERING WHEEL  
DRIVER AND PASSENGER INTERIOR SUN  
VISORS  
NO ENTRY/ACCESS/STEP WIRING

**Instruments & Controls**

GRAY DRIVER INSTRUMENT PANEL  
GRAY CENTER INSTRUMENT PANEL  
BLACK GAUGE BEZELS  
LOW AIR PRESSURE INDICATOR LIGHT AND  
AUDIBLE ALARM  
(1) SINGLE BRAKE APPLICATION AIR GAUGE  
2 INCH PRIMARY AND SECONDARY AIR  
PRESSURE GAUGES  
DASH MOUNTED AIR RESTRICTION INDICATOR  
WITH GRADUATIONS  
97 DB BACKUP ALARM  
ELECTRONIC CRUISE CONTROL WITH  
SWITCHES IN LH SWITCH PANEL  
KEY OPERATED IGNITION SWITCH AND  
INTEGRAL START POSITION; 4 POSITION  
OFF/RUN/START/ACCESSORY  
ICU3S, 132X48 DISPLAY WITH DIAGNOSTICS, 28  
LED WARNING LAMPS AND DATA LINKED  
HEAVY DUTY ONBOARD DIAGNOSTICS  
INTERFACE CONNECTOR LOCATED BELOW LH  
DASH  
2 INCH ELECTRIC FUEL GAUGE  
PROGRAMMABLE RPM CONTROL -  
ELECTRONIC ENGINE  
CHASSIS MODULE JUMPER AND BRACKET FOR  
BODY BUILDER TO RELOCATE THE CHASSIS  
MODULE INTO THE CAB  
ELECTRICAL ENGINE COOLANT TEMPERATURE  
GAUGE  
2 INCH TRANSMISSION OIL TEMPERATURE  
GAUGE  
ENGINE AND TRIP HOUR METERS INTEGRAL  
WITHIN DRIVER DISPLAY  
(1) DASH MOUNTED PTO SWITCH WITH  
INDICATOR LAMP  
ELECTRIC ENGINE OIL PRESSURE GAUGE



**Prepared for:**  
Justin Myers  
WHATCOM COUNTY PUBLIC  
WORKS  
901 W SMITH RD

BELLINGHAM, WA 98226  
Phone: 360 815 5596

**Prepared by:**  
Paul Buckel  
FREIGHTLINER NORTHWEST  
13232 CASE ROAD S.W.  
OLYMPIA, WA 98512  
Phone: 206-601-5117

---

**Description**

OVERHEAD INSTRUMENT PANEL  
AM/FM/WB WORLD TUNER RADIO WITH  
BLUETOOTH AND USB AND AUXILIARY INPUTS,  
J1939  
DASH MOUNTED RADIO  
(2) RADIO SPEAKERS IN CAB  
POWER AND GROUND STUDS IN DASH PLUS  
ROOF CONSOLE WIRING  
ROOF/OVERHEAD CONSOLE CB RADIO  
PROVISION  
MULTI-BAND AM/FM/WB/CB LH MIRROR  
MOUNTED ANTENNA SYSTEM  
ELECTRONIC MPH SPEEDOMETER WITH  
SECONDARY KPH SCALE, WITHOUT  
ODOMETER  
STANDARD VEHICLE SPEED SENSOR  
ELECTRONIC 3000 RPM TACHOMETER  
IGNITION SWITCH CONTROLLED ENGINE STOP  
FIVE ON/OFF ROCKER SWITCHES IN THE DASH  
WITH INDICATOR LIGHTS; FOUR WIRE TO  
CHASSIS AT BACK OF CAB, ONE UNWIRED,  
LABEL ALL OPT  
PRE-TRIP LAMP INSPECTION, ALL OUTPUTS  
FLASH, WITH SMART SWITCH  
BW TRACTOR PROTECTION VALVE  
TRAILER HAND CONTROL BRAKE VALVE  
DIGITAL VOLTAGE DISPLAY INTEGRAL WITH  
DRIVER DISPLAY  
SINGLE ELECTRIC WINDSHIELD WIPER MOTOR  
WITH DELAY  
MARKER LIGHT SWITCH INTEGRAL WITH  
HEADLIGHT SWITCH  
TWO VALVE PARKING BRAKE SYSTEM WITH  
DASH VALVE CONTROL AUTONEUTRAL AND  
WARNING INDICATOR  
SELF CANCELING TURN SIGNAL SWITCH WITH  
DIMMER, WASHER/WIPER AND HAZARD IN  
HANDLE  
INTEGRAL ELECTRONIC TURN SIGNAL  
FLASHER WITH HAZARD LAMPS OVERRIDING  
STOP LAMPS

**Design**

PAINT: ONE SOLID COLOR



**Prepared for:**  
Justin Myers  
WHATCOM COUNTY PUBLIC  
WORKS  
901 W SMITH RD

BELLINGHAM, WA 98226  
Phone: 360 815 5596

**Prepared by:**  
Paul Buckel  
FREIGHTLINER NORTHWEST  
13232 CASE ROAD S.W.  
OLYMPIA, WA 98512  
Phone: 206-601-5117

Color	Description
	CAB COLOR A: L0762EB MED RED ELITE BC BLACK, HIGH SOLIDS POLYURETHANE CHASSIS PAINT POWDER WHITE (N0006EA) FRONT WHEELS/RIMS (PKWHT21, TKWHT21, W, TW) POWDER WHITE (N0006EA) REAR WHEELS/RIMS (PKWHT21, TKWHT21, W, TW) STANDARD BLACK BUMPER PAINT SUNVISOR PAINTED SAME AS CAB COLOR A STANDARD E COAT/UNDERCOATING
Certification / Compliance	U.S. FMVSS CERTIFICATION, EXCEPT SALES CABS AND GLIDER KITS
Secondary Factory Options	DEALER/CUSTOMER ADVISED AND ACCEPTS BUMPER SHOULD BE REMOVED PRIOR TO RECOVERING/TOWING THE VEHICLE PER FRACAS:11687
Raw Performance Data	CALC'D FRAME LENGTH - OVERALL : 330.9 CALCULATED EFFECTIVE BACK OF CAB TO REAR SUSPENSION C/L (CA) : 120.89 in CALC'D SPACE AVAILABLE FOR DECKPLATE : 125.45 in

(\*\*\*) All cost increases for major components (Engines, Transmissions, Axles, Front and Rear Tires) and government mandated requirements, tariffs, and raw material surcharges will be passed through and added to factory invoices.



Prepared for:  
 Justin Myers  
 WHATCOM COUNTY PUBLIC  
 WORKS  
 901 W SMITH RD

BELLINGHAM, WA 98226  
 Phone: 360 815 5596

Prepared by:  
 Paul Buckel  
 FREIGHTLINER NORTHWEST  
 13232 CASE ROAD S.W.  
 OLYMPIA, WA 98512  
 Phone: 206-601-5117

## DIMENSIONS

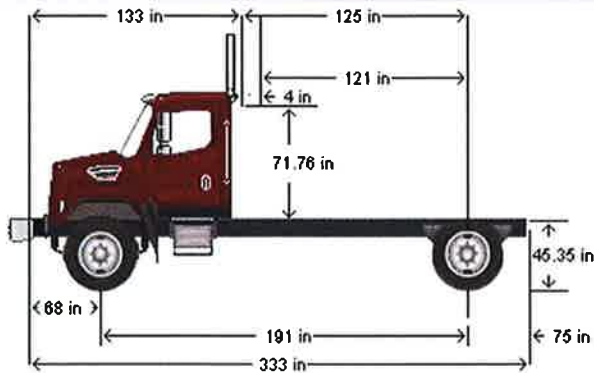

### VEHICLE SPECIFICATIONS SUMMARY - DIMENSIONS

Wheelbase (545) .....	4850MM (191 INCH) WHEELBASE
Rear Frame Overhang (552) .....	1900MM (75 INCH) REAR FRAME OVERHANG
Fifth Wheel (578) .....	NO FIFTH WHEEL
Mounting Location (577) .....	NO FIFTH WHEEL LOCATION
Maximum Forward Position (in) .....	0
Maximum Rearward Position (in) .....	0
Amount of Slide Travel (in) .....	0
Slide Increment (in) .....	0
Desired Slide Position (in) .....	0.0
Cab Size (829) .....	108 INCH BBC FLAT ROOF ALUMINUM CONVENTIONAL CAB
Sleeper (682) .....	NO SLEEPER BOX/SLEEPER CAB
Exhaust System (016) .....	RH OUTBOARD UNDER STEP MOUNTED HORIZONTAL AFTERTREATMENT SYSTEM ASSEMBLY WITH RH B-PILLAR MOUNTED VERTICAL TAILPIPE

### TABLE SUMMARY - DIMENSIONS



**Prepared for:**  
 Justin Myers  
 WHATCOM COUNTY PUBLIC  
 WORKS  
 901 W SMITH RD

BELLINGHAM, WA 98226  
 Phone: 360 815 5596

**Prepared by:**  
 Paul Buckel  
 FREIGHTLINER NORTHWEST  
 13232 CASE ROAD S.W.  
 OLYMPIA, WA 98512  
 Phone: 206-601-5117

Dimensions	Inches
Bumper to Back of Cab (BBC)	133.3
Bumper to Centerline of Front Axle (BA)	67.7
Min. Cab to Body Clearance (CB)	3.0
Back of Cab to Centerline of Rear Axle(s) (CA)	125.4
Effective Back of Cab to Centerline of Rear Axle(s) (Effective CA)	120.9
Back of Cab Protrusions (Exhaust/Intake) (CP)	0.0
Back of Cab Protrusions (Side Extenders/Trim Tab) (CP)	4.5
Back of Cab Protrusions (CNG Tank)	0.0
Back of Cab Clearance (CL)	4.5
Back of Cab to End of Frame	200.2
Cab Height (CH)	71.8
Wheelbase (WB)	190.9
Frame Overhang (OH)	74.8
Overall Length (OAL)	333.5
Rear Axle Spacing	0.0
Unladen Frame Height at Centerline of Rear Axle	45.3

Performance calculations are estimates only. If performance calculations are critical, please contact Customer Application Engineering.







**Jon Hutchings**  
Director

**Eric L. Schlehuber, Division Manager**

**MEMORANDUM**

**To:** Brad Bennett, AS Finance Manager  
**Through:** Jon Hutchings, Public Works Director   
**From:** Eric L. Schlehuber, PW Equipment Services Manager   
**Date:** November 6, 2019  
**Re:** Purchase of one (1) 2021 Dump Body, Hook Lift Sander and Plow  
 (State Contract #01117, Dump Bodies, Snow Plows Various Types, Controls & Services)

**Requested Action**

After researching costs of dump truck bodies, hook lift sanders and plows, I am requesting Executive approval to purchase one (1) 2021 Dump Body, Hook Lift Sander and Plow from the Washington State Bid Procurement List (Contract #01117, Dump Bodies, Snow Plows Various Types, Controls & Services). The current state contract is for the period of May 1, 2019 through May 1, 2020. The hook lift sander and plow will be used to replace the following units:

DEPARTMENT	REPLACE UNIT	YEAR / MAKE / MODEL
M&O	213	1988 International 5 YD Single Axle Dump Truck
M&O	456	2000 Swenson Sander
M&O	596	12' Steel Snow Plow

**Background and Purpose**

The dump truck cab, truck bed and chassis (#213), were approved for replacement in the 2019-2020 Equipment Rental and Revolving Capital Equipment Budget to be used by Whatcom County Public Works. There adequate unspent capital budget authorities for the upgrades to the hook lift sander and plow, and upgrade for 4x4. The Maintenance and Operations Division will use this 5yd Single Axle 4x4 Dump Truck with hook lift sander and plow regularly in the performance of county business. The cab and chassis will be submitted under a separate bid award request memo.

VENDOR	YEAR / MAKE / MODEL	QTY	PRICE EACH	SALES TAX TOTAL (8.5%)	EXTENDED TOTAL
Northend Truck Equipment	2021 Dump Body, Hook Lift Sander and Plow	1	\$133,809.40	\$11,373.80	\$145,183.20

**Funding Amount and Source**

The replacement of the truck body was budgeted under the replacement of the unit #213. This unit was budgeted during the 2019-2020 budget process in the amount of \$165,000.00. To correct a budgeting error, an additional \$100,000 budget transfer was approved in 2019 to upgrade the vehicle to 4x4 with a hook lift bed, for a total of \$265,000 (10% allowance of \$291,500.00). The cab and chassis were requested under a separate bid award in the amount of \$136,494.67. The remaining amount of \$45,001.90, along with sufficient unspent capital budget authority of \$100,000, provide a remaining budgeted amount of \$145,001.10. I am requesting Executive and Council approval to purchase these units from Northend Truck Equipment of Marysville, Washington for the price of \$133,809.40, plus 8.5% sales tax of \$11,373.80 for a total amount of \$145,183.20. A separate bid award request

for the cab and chassis is concurrently in process in the amount of \$136,494.67 bringing the total for both truck, truck bed and hook lift to \$281,677.87, which is within the 10% allowance.

- **Recommended Action**

Please approve this purchase and forward to the Executive and County Council for approval at the November 19, 2019 County Council Meeting. Please contact Eric L. Schlehuber at extension 6405 if you have any questions or concerns.



Quote# 190605WC

10/29/2019

R.1

Price Quotation For

# Northend Truck Equipment

14919 - 40th Ave. N.E.  
Marysville, WA 98271

Ph: 360-653-6066 Fax: 360-653-0100  
1-800-653-6066

Visit Our Web Site - [www.northendtruck.com](http://www.northendtruck.com)

**Prepared For:**

Justin Myers  
Whatcom County PW  
Maintenance Supervisor  
360-815-5596

[jMyers@co.whatcom.wa.us](mailto:jMyers@co.whatcom.wa.us)

**State of Washington Current Contract Information:**

Effective Date: 05-01-2018  
Contract number: 01117  
Contract title: DUMP BODIES, SNOW PLOWS VARIOUS TYPES,  
CONTROLS & SERVICES

Excel#	Item #	Category	QTY	Unit Price	Total Price
<b>Dump Body Category A (Sanders)</b>					
63	-	Monroe 11' V-Hopper Sander	1	\$27,074.00	\$27,074.00
		Hook-Lift Skid, to include tip up spinner modifications so as to not interfere with loading and unloading of the unit. Manual hand winch to tip up spinner assembly shall be accessible from the ground and have friction brake. Winch cable to run through an upper pulley attached to an extended bolt on bracket located near the top of the rear panel with a guide roller at rear of the tail section to include a second pulley near the bottom of the spinner assembly for ease of lifting. Hooklift skid must be capable of being loaded/unloaded from the chassis at maximum rated hopper capacity.	1	\$2,637.00	\$2,637.00
91	21	Deduct for no prewet system	1	-\$3,284.00	-\$3,284.00
<b>Dump Body Category C (Dump Bodies)</b>					
101	17	Steel Tool Box 18 x 18 x 36, CA Room Permitting (Installed) Location Determined At Time Of Order	1	\$650.00	\$650.00
114	3	5-6 Yard Skid Mounted Dump Body to Include Stucchi Multi Connector with Air and Electrical to Reach Back of Cab Per DOT Spec's (11' Long)	1	\$17,868.00	\$17,868.00
118	7	Steel Rollers For Hook Lift Skid	1	\$648.00	\$648.00
139	28	Ladder Rung Walk Rails I.L.O. Rebar	1	\$357.00	\$357.00
<b>Dump Body Category G (Palift &amp; Options)</b>					
16	1	Palift T-29 For Single Axle Chassis	1	\$27,851.00	\$27,851.00
<b>Category G: NTE (Additional Products And Services)</b>					
<b>Hitch Options</b>					
30	2	580 None Air Hitch With "D" Rings Installed Complete With OEM Gladhands Seven Way Plug, Back-up Alarm, and Tail Lights	1	\$1,985.00	\$1,985.00
32	4	Full Width Tube Style ICC Bumper With LED Sealed Beam Stop, Turn, Tail Lights Includes Alt. Flash (Does Not Include Hitch)	1	\$1,288.00	\$1,288.00





Quote# 190605WC

10/29/2019

## Northend Truck Equipment

14919 - 40th Ave. N.E.

Marysville, WA 98271

Ph: 360-653-6066 Fax: 360-653-0100

1-800-653-6066

Visit Our Web Site - [www.northendtruck.com](http://www.northendtruck.com)

<b>Fender Options</b>					
41	g.	Steel Fender Set For Single Axle Painted Black With Radius Both Ends	1	\$1,563.00	\$1,563.00 ✓
<b>Tarp And Rack Options</b>					
45	2	Back Of Cab T-Rack To Include (2) Whelan L-31 And (1) LED Work Light	1	\$1,842.00	\$1,842.00 ✓
<b>NTE Basic Hydraulics</b>					
23	1	Closed Center Snow and Ice System Multi Section Valve With 5100EX Electric Sander Valve Control and Stainless Box (Room Permitting) With Load Sense Pump Front Mounted With OEM Front Frame Rail Extensions, Electric Ultra Arm Control Console, Behind The Cab Tank, or VT35 with Poly Or Stainless Lid, With Basic Hoses and Fittings Installed (See Sander Line Option)	1	\$24,375.00	\$24,375.00 ✓
58	10	Stucchi Multi Connector, Fixed and Mobile Half For Sander Includes Parking Station and Cover	1	\$2,045.00	\$2,045.00 ✓
59	11	Sander Lines The Rear With QD's	1	\$1,344.00	\$1,344.00 ✓
<b>Plow Category 2</b>					
10	-	Henke Flatplate Hitch (requires extended front frame rails and stationary grill)	1	\$2,978.00	\$2,978.00 ✓
16	-	4x4 Truck (Add)	1	\$698.00	\$698.00 ✓
19	-	Truck-Lite #80800 plow lights, to be hooked up to Chassis provided wiring and switch , Includes Adjustable Stainless Steel Brackets (Installed)	1	\$825.00	\$825.00 ✓
<b>Plow Category 3</b>					
25	1	Slotted Trips in lieu of shear bars	1	\$1,439.00	\$1,439.00 ✓
30	6	12' Reversible Parallel Lift "Short" Batwing Plow ***11 ft Plow In Lieu Of 12 ft ***	1	\$12,952.00	\$12,952.00 ✓
37	1	Henke Plow shipped to Northend Truck set up and tested with plumbing and Stucchi, test and adjust float pressure. Ship with completed unit.	1	\$975.00	\$975.00 ✓
<b>Parts and Service (Parts Needed)</b>				<b>List Price</b>	<b>20% Discount</b>
43	21	NE-19E DLA/Anti-Icing 3-Lane Harness Kit to Add to 5100ex-3 Harnessing (Flow Meter Feedback Incl.)	1	\$1,078.88	\$863.10 ✓
45	23	NE-21E Hot Shift PTO (280 Series), Direct Mount Load Sense Pump for Allison 3000 & 4000 Series	1	\$2,354.63	\$1,883.70 ✓
46	24	NE-22E High Pressure Hooklift Valves and Controls	1	\$3,690.75	\$2,952.60 ✓
<b>Total With Quantity Items Selected</b>					<b>\$133,809.40</b>
Applicable Sales Tax Percentage at Delivery Location				<b>8.50%</b>	<b>\$11,373.80</b>
<b>Total Price with Tax Included</b>					<b>\$145,183.20</b>



Quote# 190605WC

10/29/2019

## Northend Truck Equipment

14919 - 40th Ave. N.E.

Marysville, WA 98271

Ph: 360-653-6066 Fax: 360-653-0100

1-800-653-6066

Visit Our Web Site - [www.northendtruck.com](http://www.northendtruck.com)

### Notes:

- Body Color: Silver
- Plow Color: Orange
- Tool Box Color: White
- New chassis to have 120" of usable CA
- New chassis to be equipped with extended front frame rails (not bolt on) and stationary grill.

Accepted: *Zack Andrews*

10/29/2019

Accepted: \_\_\_\_\_

Date: \_\_\_\_\_

Zack Andrews

Justin Myers

**NORTHEND TRUCK EQUIPMENT**

Whatcom County PW

PO# \_\_\_\_\_

Thank You for your help on this, if you have any questions or need additional information  
Please call or email me at 425-903-2207, [ZackA@northendtruck.com](mailto:ZackA@northendtruck.com)

Sincerely,

**NORTHEND TRUCK EQUIPMENT**

Zack Andrews

Sales