

FACILITIES 2026 SPRING UPDATE

APRIL 2026



WHAT HAS FACILITIES BEEN WORKING ON THIS YEAR? JUST THE JAIL?

- ▣ FACILITIES IS CURRENTLY WORKING ON 39 ACTIVE PROJECTS, THE JUSTICE PROJECT IS ONLY ONE OF THEM

ACTIVE PROJECTS

- ▣ SECURITY UPGRADES TO THE COURTHOUSE- This has been an on-going project since 2020, including replacing the access control hardware, expanding our video surveillance coverage, and other improvements that increase security for the Court Systems and staff.
- ▣ SHERIFF OFFICE AND 32ND STREET TENANT IMPROVEMENT DESIGNS-Two new buildings that require improvements to function optimally for future tenants.
- ▣ PUBLIC DEFENDER TENANT IMPROVEMENT DESIGN- Converting existing cubical offices to hardened offices to allow attorney/client private conversations.

- ▣ JUST TO NAME A FEW

COMPLETED PROJECTS AND VICTORIES- ALL BASED ON ADDITIONAL SERVICE REQUESTS APPROVED BY COUNCIL

- ▣ 5TH SUPERIOR COURTROOM/IT MOVE
- ▣ PROSECUTING ATTORNEY OFFICE RECONFIGURATION, PHASE 1
- ▣ SUPERIOR COURT CLERK LOBBY SECURITY IMPROVEMENTS
- ▣ AUDITOR OFFICE LOBBY SECURITY IMPROVEMENTS
- ▣ ASSESSOR OFFICE RECONFIGURATION

5TH SUPERIOR COURT COURTROOM PROJECT SCOPE

- ▣ STEP 1- MOVE IT OUT OF 3RD FLOOR SUITE
- ▣ PURCHASE 400 NORTH COMMERCIAL STREET PROPERTY
- ▣ DESIGN NEW COURTROOM (IN HOUSE DESIGN AND PERMITTING)
- ▣ CONTRACT TENANT IMPROVEMENTS
- ▣ COMPLETE PROJECT WITHIN BUDGET (BARELY, BUT WE MADE IT)
- ▣ KNOWN IMPROVEMENTS TO 400 NORTH COMMERCIAL STREET BUILDING (WATER INTRUSION, SECURITY (ALL SELF PERFORMED BY FACILITIES STAFF))

5TH SUPERIOR COURT COURTROOM

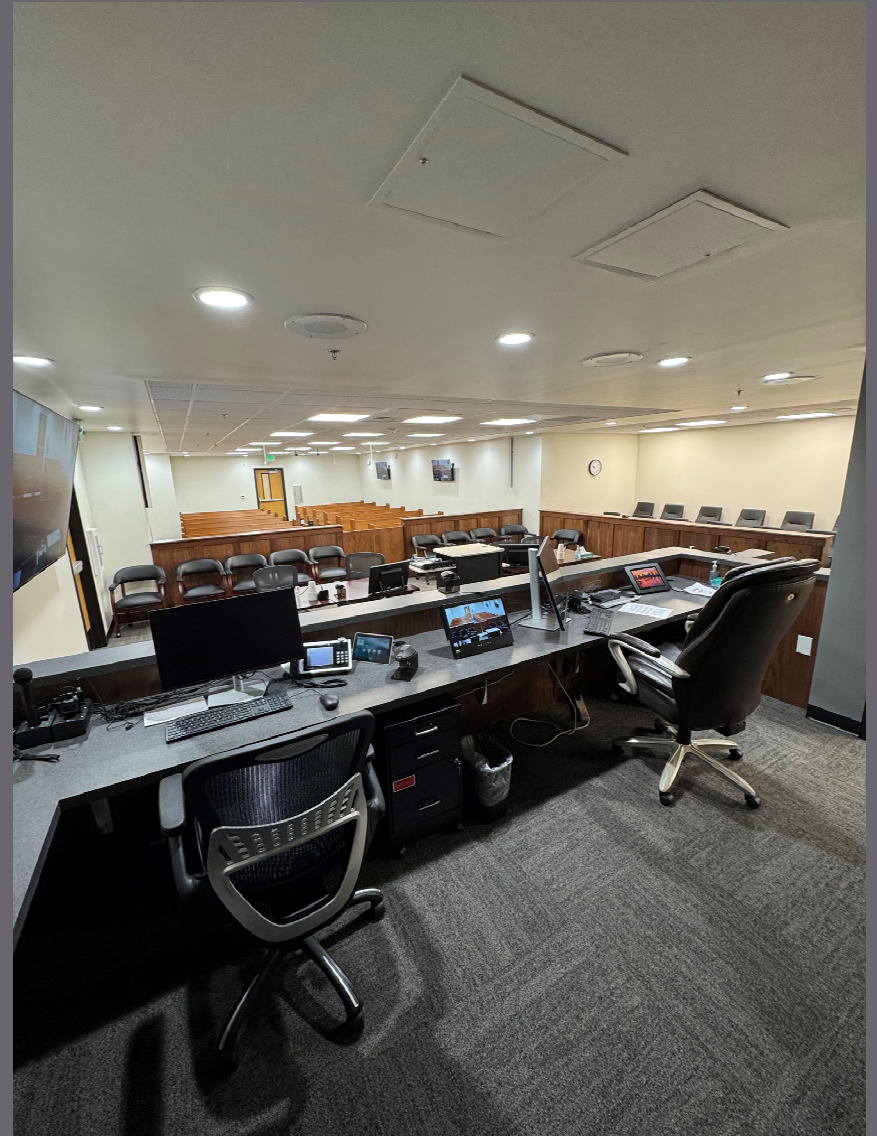

5TH SUPERIOR COURT COURTROOM



IT MOVE TO 400 NORTH COMMERCIAL/BASEMENT TI (SELF PERFORMED)



IT MOVE TO 400 NORTH COMMERCIAL/BASEMENT TI (SELF PERFORMED)



400 NORTH COMMERCIAL WATER INTRUSION WORK

(SELF PERFORMED)

- ▣ PREVIOUS OWNER WAS VERY FORTHCOMING OF HISTORICAL WATER INTRUSION ISSUES DUE TO LEAKS IN ROOF.



PROSECUTING ATTORNEY OFFICE RECONFIGURATION, PHASE 1



SUPERIOR COURT CLERK LOBBY SECURITY IMPROVEMENTS



ASSESSOR OFFICE RECONFIGURATION



WHAT IS UNDERWAY

- ▣ SUPERIOR COURT DEPARTMENT 2 ADA DOOR/SECURITY IMPROVEMENTS
- ▣ NEXT PHASE OF COURTHOUSE EXTERIOR PROJECT- BID, CONTRACT AWARD IN NEXT FEW WEEKS, WORK THIS SUMMER (PROJECT THAT BEGUN IN 2015)
- ▣ HEALTH DEPARTMENT LOBBY SECURITY IMPROVEMENTS (SECURITY GLASS, ADDITIONAL CAMERAS, PUBLIC BARRIERS TO RESTRICT PUBLIC TO STAFF AREAS.

SUPERIOR COURT DEPARTMENT 2 ADA/SECURITY IMPROVEMENTS (SELF PERFORMED)



COURTHOUSE EXTERIOR PROJECT 2026 SUMMER PROJECT

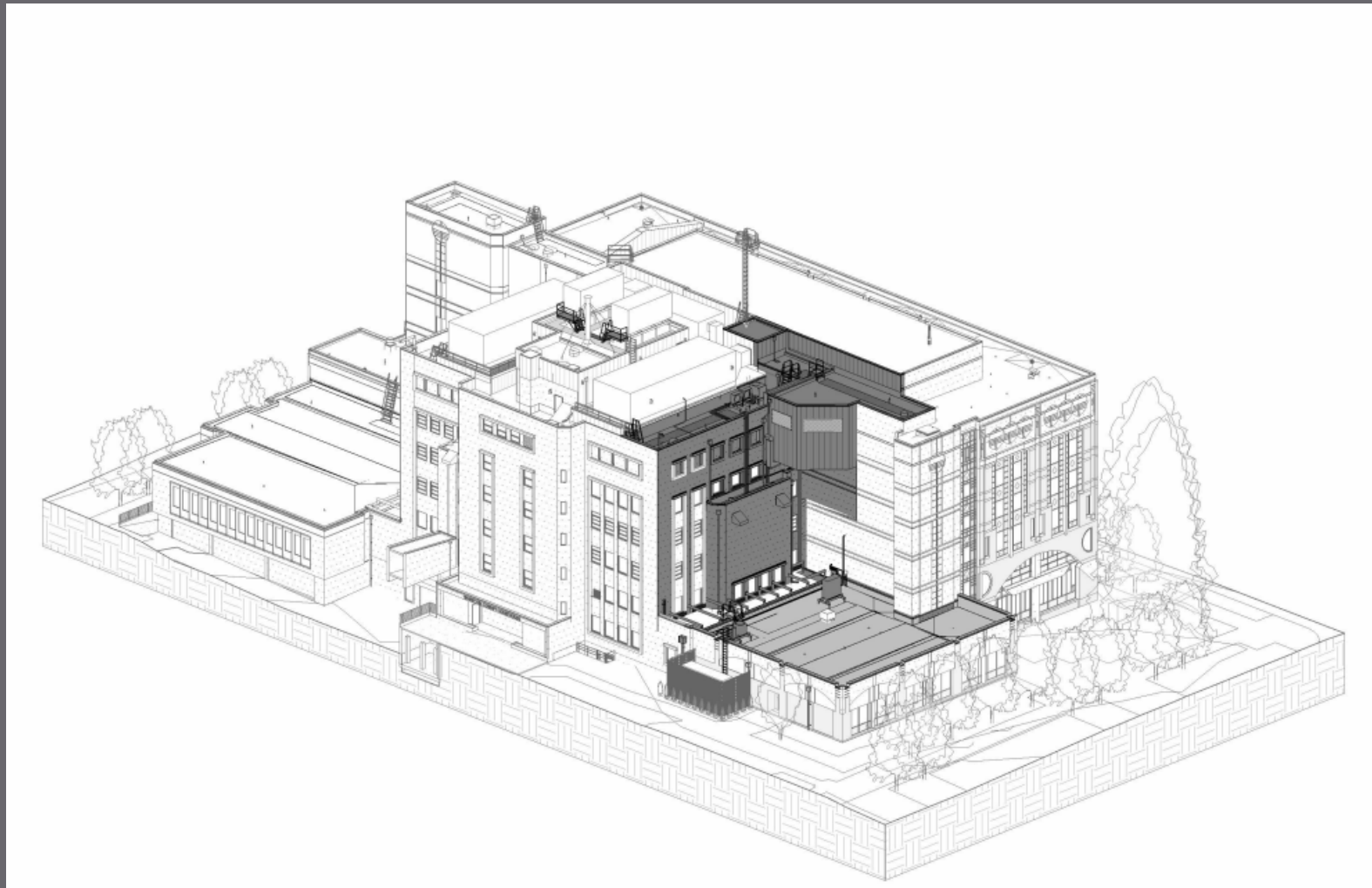

HEALTH DEPARTMENT LOBBY SECURITY IMPROVEMENTS

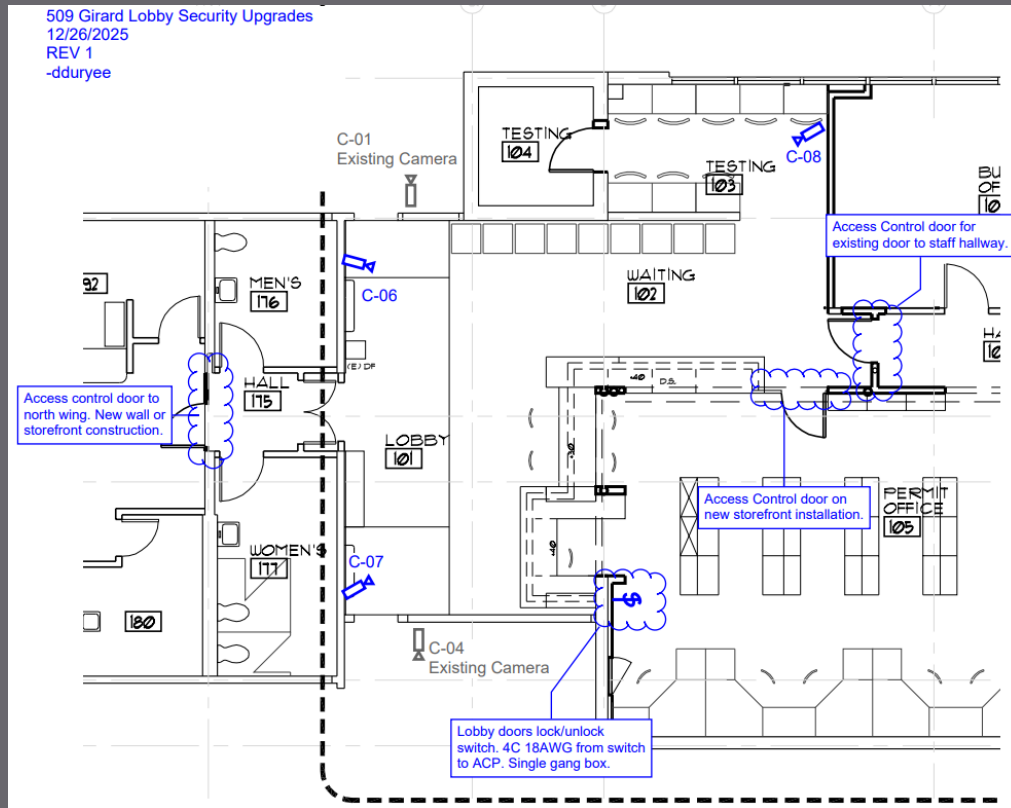
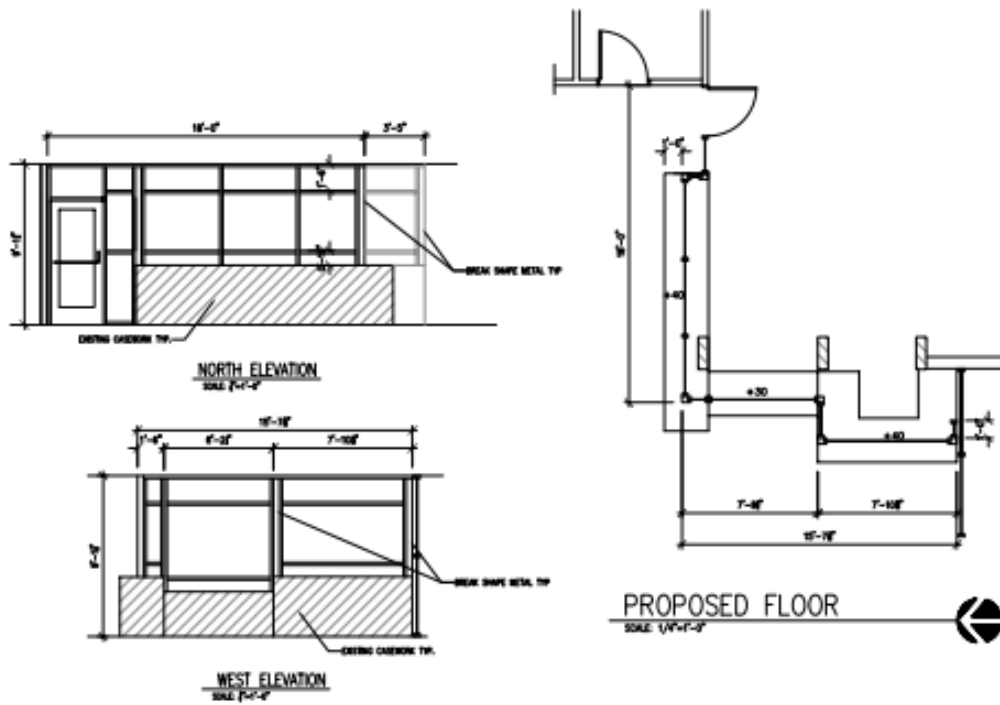

FACILITIES BUNCH

