

**WHATCOM COUNTY
SHERIFF'S OFFICE**
DONNELL "TANK" TANKSLEY
Sheriff



PUBLIC SAFETY BUILDING
311 Grand Avenue
Bellingham, WA 98225
(360) 778-6600

MEMO TO: The Honorable Members of the Whatcom County Council; and
The Honorable Satpal Singh Sidhu, County Executive

THROUGH: Brad Bennett, Finance Manager

FROM: Donnell Tanksley, Sheriff
Steve Harris, Undersheriff
James Triplett, Chief Deputy

DATE: June 26, 2024

RE: Recommend to Award Bid #24-64 – Supply of Night Vision Goggles with Helmet Mounts

Background

Bids were duly advertised for the purchase of 16 pair of night vision goggles with helmet mounts. The Sheriff's Office will issue these night vision goggles to commissioned deputy sheriff officers to use in the performance of law enforcement functions.

Seven (7) bids were received on Tuesday, June 18, 2024. Four (4) bids were declared unresponsive due to not submitting completed bid documents, and one (1) bid did not meet the minimum requirements of the bid specifications. Steele Industries, Inc., located in Bradenton, Florida, submitted the lowest responsive and responsible bid, as noted below:

BIDDER	TOTAL BID (includes 9.0% sales tax)
Steele Industries Inc	\$ 190,979.27
TNVC Inc	\$ 203,161.28
Lawmen's and Shooter's Supply Inc	\$ 151,873.49
Maxavision Technologies	\$ 221,711.45
GovSmart Inc	\$ 149,526.72¹
Arms Unlimited	\$ 177,104.00
Venture Tactical LLC	\$ 120,041.70

¹ Sales tax was not noted on Bid Response received from GovSmart Inc; input applicable rate of 9.0% for Total Bid Amount, per bid document.

Funding Amount and Source

Funding for this purchase was approved in the General Fund by Council on Supplemental ID #2024-4589 (2024 Stonegarden FY20), as appropriated on Ordinance #2024-018. A budget modification was subsequently approved by the County Executive transferring the funds to the capital line item, as these night vision goggles meet the definition of a capital asset.

Requested Action

The Sheriff's Office requests the County Council and County Executive's approval to award Bid #24-64 to Steele Industries Inc., in the amount of \$190,979.27.

Questions

Please contact James Triplett, extension 6725, if you have any questions or concerns regarding this request.

**WHATCOM COUNTY
SHERIFF'S OFFICE**
DONNELL "TANK" TANKSLEY
Sheriff



PUBLIC SAFETY BUILDING
311 Grand Avenue
Bellingham, WA 98225
(360) 778-6600

Recommendation

In accordance with WCC 3.08.030, I concur with this recommendation, and forward such to the County Council and County Executive for approval, per WCC 3.08.100(A).

A handwritten signature in blue ink that reads "Brad Bennett".

Brad Bennett, AS Finance Manger

6/27/24

Date

Approved as recommended:

County Executive

Date of Council Action

Whatcom County
Bid #24-64
Night Vision Goggles with Helmet Mounts

Bid Response Forms

The bidder hereby acknowledges that they have read and understand all the specifications and bidding requirements. The bidder also acknowledges that any bid submitted which does not meet the minimum specifications may be deemed unresponsive and rejected on that basis.

- Please complete and include all pages of the Bid Response Forms.
- Please print (in ink) or type all information on the Bid Response Forms, with exception to the signature field.
- Bidder may attach additional pages for comments on Minimum Specifications. Clearly reference to the applicable specification.

Company Name Steele Industries INC

Address 10510 Portal Crossing, Unit 101, Bradenton FL 34211

Submitted By Tyler Liberto - Account Executive
(Print Name & Title)

Signature  Phone 941-773-0682

E-Mail tylerl@steeleindinc.com

Submit Sealed Bids Before: **2:30 PM Tuesday, June 18, 2024**

Deliver Bids To: Whatcom County AS-Finance/Purchasing
311 Grand Avenue Suite 503, Bellingham, WA 98225

F.O.B. Delivery Point: Whatcom County Sheriff's Office, Public Safety Building
311 Grand Avenue, Bellingham, WA 98225

We are offering to supply the following items in full accordance with the attached bid specifications.

ITEM	DESCRIPTION	PRICE EACH <small>(Excluding freight/sales tax)</small>	EXTENDED PRICE FOR 16 QTY
1.	Night Vision Goggles with Helmet Mounts	\$ 10,930.96	\$ 174,895.36
		Freight	\$ 314.98
		Subtotal	\$ 175,210.34
		Sales Tax @ 9.0%	\$ 15,768.93
		TOTAL BID FOR 16 UNITS	\$ 190,979.27

Bidder acknowledges receipt of Addenda by checking the box(es): 1 2 3 4

Days to deliver after receipt of order: 60 Days ARO

Prompt payment discount offered: No

5-year Warranty offered at no cost: Yes

ADDITIONAL LIKE UNIT PURCHASING FOR COUNTY

The County may choose to purchase additional like units at the same proposal terms and pricing for two years from date of award of Bid #24-64. Yes No

WA STATE INTERLOCAL COOPERATIVE ACT 39.34

Other municipalities or political subdivisions may purchase the same goods at the same proposal terms and pricing, from the vendor for a period of two years from date of award of Bid #24-64. Participation is not mandatory. Yes No

Whatcom County
Bid #24-64
Night Vision Goggles with Helmet Mounts

MINIMUM SPECIFICATIONS	MEETS SPECIFICATIONS?
Unless otherwise noted, the specifications listed are <u>minimum</u> limits.	YES – NO – COMMENT
GOGGLES	
Maximum Dimensions: 4.6"(L) X 4.5"(W) X 3.6"(H)	Yes
Maximum Weight: 19.7 oz (Including Battery)	Yes
Finish: Matte Black, Corrosion Resistant	Yes
Power: Maximum One (1) AA Battery (On-board)	Yes
Remote Battery Pack: Powered by a Maximum of Four (4) AA Batteries	Yes
Battery Life: >15 hrs (Device), or >50 hrs (Remote)	Yes
Waterproof: 66' for 2 hrs	Yes
Flashbang/Diversinary Device Protection Circuit	Yes
Generation: Gen3 Unfilmed	Yes
Tube: 18mm MX-11769 Variable Gain, White Phosphor	Yes
Figure of Merit (FOM) (SNR x lp/mm): 2376	Yes
Gate: Auto	Yes
Gain: Adjustable/Variable	Yes
Magnification: 1x	Yes
FOV: 40°	Yes
Objective Focus: 10" to Infinity	Yes
Diopter: Adjustable +2 to -6	Yes
Dual Tube Goggle	Yes
Padded MOLLE Carry Pouch	Yes
Rubber Eye Cups	Yes
Sacrificial Windows	Yes
Lens Covers	Yes
Remote Power Cable	Yes
MIL-STD-810 Standards	Yes
HELMET MOUNTS	
Lightweight Aerospace Aluminum, Polymer	Yes
Height Adjust: 0.900" Total Vertical Travel	Yes
View to Stow: 130° Travel	Yes
Finite Tilt: 0-15° Tilt	Yes
Travel: 1.400" Total Fore/Aft Travel	Yes
Auto On-Off	Yes
Color: Tan or Green	Yes - Tan
WARRANTY	
5-Year Warranty on Goggles at No Additional Cost	Yes
MISCELLANEOUS	
Operator's Manuals: One Manual for Each Purchased Unit	Yes

Whatcom County
Bid #24-64
Night Vision Goggles with Helmet Mounts

References

If you *have not* done business with Whatcom County in the past five (5) years, please provide the following reference information for other government entities that you have sold similar pieces of equipment to in the last two (2) years.

Name:	Manatee County Sheriff's Department
Address:	600 Highway 301 Boulevard West, Bradenton FL 34205
Contact Name:	Hilda Urbina
Phone Number:	(941) 747-3011 x 2282
Fax Number:	N/A
Email:	Hilda.Urbina@manateesherriff.com

Name:	West Valley City Police Department
Address:	3577 South Market Street, West Valley City, UT 84119
Contact Name:	Tyler Thompson
Phone Number:	801-509-1648
Fax Number:	N/A
Email:	Tyler.Thompson.wvc-ut.gov

Name:	City Of Brownsville Police Department
Address:	600 East Jackson St., Brownsville, TX 78520
Contact Name:	David Jaramillo
Phone Number:	956-548-7109
Fax Number:	N/A
Email:	david.jaramillo@brownsvilletx.gov



BNVD-1531

Binocular Night Vision Device

CHARACTERISTICS	
Dimensions	4.6 in. L x 4.5 in. W x 3.6 in. H
Weight	< 560 g (1.23 lb.) with AA Lithium battery installed and adjustable diopter (no accessories)
Battery Type	(1) AA Lithium
Battery Life	≥ 16 hrs. avg. at 25 °C (77 °F) ≥ 50 hrs. avg. at 25 °C (77 °F) on (4) AA Lithium batteries with optional 4-cell battery pack
Field-Of-View	40° ± 2° deg. (circular)
Objective Focus	10 in. (25 cm ±3 cm) to infinity
Eyepiece Diopter	Adjustable from +2.0 to -6.0
Image Intensification	U.S. manufactured MX-11769 Gen III variable gain tubes
Environmental	Meets MIL-STD-810

FEATURES

- > Includes Gen III I² tubes with auto-gated technology to prevent damage in high-light environments
- > High-performance white phosphor image with enhanced degree of detail in overall contrast and range of shades while providing the operator with more visual information for accurate assessment and acquisition
- > Manual system gain and focus adjustments for custom image quality optimization
- > Lightweight ergonomic design reduces head-borne weight and decreases neck strain
- > Adjustable diopter eyepieces allows use by operators with differing visual acuity
- > Integrated infrared illuminator for map reading
- > Rotating binocular design allows low profile against helmet when in stowed position and the option to use as a single monocular
- > Works with currently fielded dovetail helmet mounts
- > Auto OFF when stowed; resumes power when deployed
- > LED indicators in left and right monocular alert the operator when the BNVD has no less than 10 minutes of battery life remaining
- > Replaceable/upgradeable I² tube assemblies



The L3Harris BNVD-1531, the newest addition to our extensive portfolio of Image-Intensification (I²) systems, combines the most-desired features from the rugged, battle-proven AN/PVS-15 and AN/PVS-31 to deliver additional capability to the warfighter in a small, lightweight package.

The 1531 is the result of the L3Harris focus on continuous product improvements in the areas of size, weight, performance and power consumption. The 1531 offers a lightweight, ergonomic design similar to the AN/PVS-31 but with significant weight reduction over the AN/PVS-15. It also incorporates features such as: adjustable diopters, manual gain adjustment, individually rotating monoculars and an integrated infrared illuminator. The 1531 can be operated as a helmet-mounted, head-mounted or handheld system and is field maintainable with limited equipment.

The 1531 is provided with high-performance, Gen III image intensifiers manufactured by L3Harris. They feature auto-gating power supplies and are available in green (P43) or white phosphor (P45) at performance levels ranging from 1600 to greater than 2376 Figure of Merit. The L3Harris white phosphor technology provides the warfighter with greater target detection and recognition. Low-light and nighttime maneuvers appear more natural in black and white, with added contrast detail in shapes and shadows, providing the operator more visual information for assessment and acquisition.

The 1531 is the best-value solution to deliver night vision capability that is interchangeable across multiple operators.



BNVD-1531 Binocular Night Vision Device

© 2020 L3Harris Technologies, Inc. | 08/2020 | r5a-1

Use of U.S. Department of Defense (DoD) visual information does not imply or constitute DoD endorsement.

This document consists of basic marketing information that is not defined as technical data under ITAR Part 120.10. Export of this product is regulated by the U.S. Department of State in accordance with guidelines of "International Traffic Arms Regulations (ITAR)". Specifications are approximate and subject to change without notice.

L3Harris Technologies is an agile global aerospace and defense technology innovator, delivering end-to-end solutions that meet customers' mission-critical needs. The company provides advanced defense and commercial technologies across air, land, sea, space and cyber domains.



L3HARRIS™
FAST. FORWARD.

1025 W. NASA Boulevard
Melbourne, FL 32919
t 866 509 2040
Quotes.Insight@L3Harris.com

G24

BREAKAWAY NIGHT VISION GOGGLE MOUNT

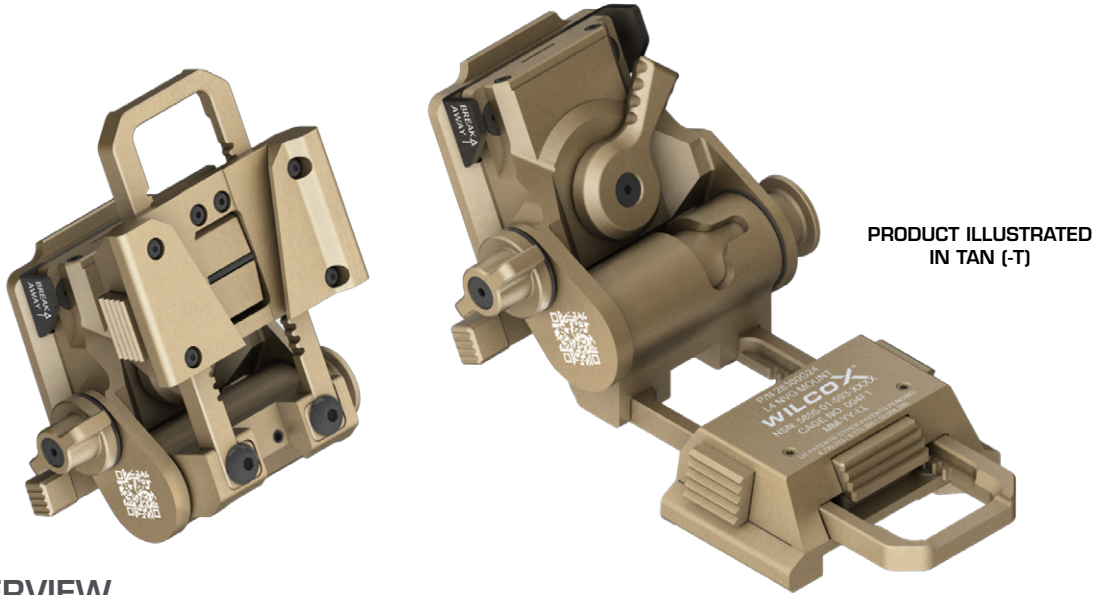

PRODUCT OVERVIEW

The Wilcox G24® low profile breakaway mount has become the industry standard for night vision goggle mounting solutions. With a dovetail shoe interface, the G24 offers near universal mounting compatibility. During the G24’s initial development, extensive operational input was considered and since it’s initial fielding, millions of operational hours have established operator muscle memory. Pioneering the “break away” feature, safety is built into this mount’s design; Under stress, the mount will break away from the base, reducing the potential for neck injury. This mount can be summarized in one word – quality. The superior finish, attention to design and functionality, the G24 optimizes the use of your night vision goggle.

NVG COMPATIBILITY

- AN/PVS-15, AN/PVS-18, AN/PVS-31/BNVD
- GPNVG-18 (DOVETAIL), AN/PSQ-36 FGS (DOVETAIL)

**Other NVG/THERMAL devices are compatible but require additional accessories. Please call customer service for more information.*

FEATURES & BENEFITS

- Maintains a very low profile on the helmet
- Ergonomic adjustments allow for one handed operation
- Breakaway feature reduces the risk of neck injury
- Dovetail shoe interface securely locks NVG’s into place
- Compatible with all Wilcox shrouds
- 5 Year Standard Limited Warranty

SPECIFICATIONS

Dimensions:	3.98" L x 2.60" W x 2.40" H
Weight:	5.86 OZ
Fore/Aft Travel:	>1.3"
Height Adjustment:	.90"

Available Colors: -T -B

PRODUCT DESCRIPTION	NSN NUMBER	PART NUMBER
G24 MOUNT	5855-01-593-6422 [B] 5855-01-593-6375 [T]	28300G24
G24 NON-BREAKAWAY BASE/MAGNET		28300G22
G24 BREAKAWAY BASE/MAGNET/ ONE HOLE SHROUD STANDARD/LANYARD		28300G37
G24 BREAKAWAY BASE/MAGNET/ THREE HOLE SHROUD STANDARD/LANYARD/CUP		28300G70
G24 BREAKAWAY BASE/MAGNET/ THREE HOLE SHROUD HYBRID/LANYARD/CUP		56100G41

Approved for Public Release



G24

BREAKAWAY NIGHT VISION GOGGLE MOUNT - KITS



G37 KIT
G24, ONE-HOLE SHROUD & LANYARD
(MICH/ACH)



G70 KIT
G24, THREE-HOLE SHROUD & LANYARD



G41 KIT
G24, HYBRID SHROUD & LANYARD

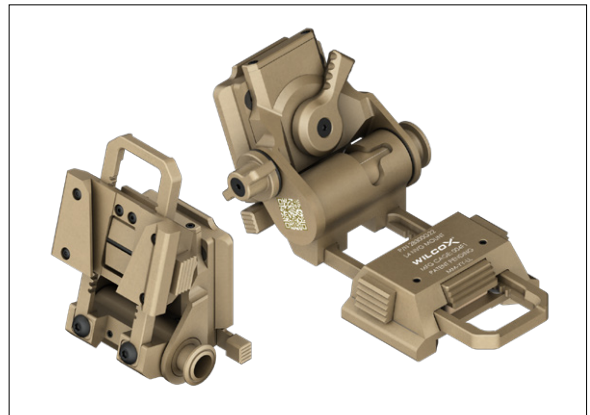

G22 MOUNT
G24 NON-BREAKAWAY BASE/MAGNET



Supplemental Budget Request

Status: Pending

Sheriff

Operations

Suppl ID # 4589

Fund 1

Cost Center 1003521001

Originator: Donna Duling

Expenditure Type: One-Time Year 2 2024 Add'l FTE Add'l Space Priority 1

Name of Request: 2024 Stonegarden FY20

X

Department Head Signature (Required on Hard Copy Submission)

2/22/24

Date

Costs:	Object	Object Description	Amount Requested
	4333.8705	St Homeland Sec Grt Prg	(\$288,411)
	6140	Overtime	\$19,608
	6210	Retirement	\$1,039
	6230	Social Security	\$1,500
	6259	Worker's Comp-Interfund	\$433
	6269	Unemployment-Interfund	\$51
	6510	Tools & Equip	\$258,186
	6790	Travel-Other	\$941
	7060	Repairs & Maintenance	\$1,600
	Request Total		(\$5,053)

1a. Description of request:

The U.S. Department of Homeland Security (DHS) Federal Emergency Management Agency (FEMA) awarded \$405,600.00 to Whatcom County for FY20 Operation Stonegarden (OPSG) Grant Program to enhance cooperation and coordination among local, tribal, state, and federal law enforcement agencies in a joint mission to secure the borders of the United States. The Sheriff's Office and other law enforcement agencies in the area will use OPSG funding to provide enhanced patrols to increase law enforcement presence in maritime and land border areas of Whatcom County targeting illicit activity, specifically cross border human trafficking, smuggling, weapons, currency, and narcotics., WCC#202104016.

None of the grant funds were used in 2021, \$351,336 were used in 2022 and \$197.43 were used in 2023, leaving \$54,066.57 for 2024. An additional \$234,343.94 was awarded in 2024 (AB2024-143) for a total budget of \$288,410.51.

State and local law enforcement agencies are not empowered to enforce immigration laws under the OPSG program.

1b. Primary customers:

Citizens of Whatcom County

2. Problem to be solved:

Budget authority is needed to use OPSG FY20 funds in 2024. Equipment budget will be used for one (1) drone and sixteen (16) nightvision goggles. The balance of the revenue will be used for regular time and related benefits. A buget transfer was created for \$5,053.

3a. Options / Advantages:

OPSG funds are awarded specifically for projects that improve border security. They cannot be used for any other purpose.

Supplemental Budget Request

Status: Pending

Sheriff

Operations

Suppl ID # 4589

Fund 1

Cost Center 1003521001

Originator: Donna Duling

3b. Cost savings:

4a. Outcomes:

Enhanced patrols will be conducted per contract specifications and timelines. Daily Activity Reports will be completed and sent to the Homeland Security.

4b. Measures:

The Whatcom County Sheriff's Office and U.S. Border Patrol, Blaine Sector, will monitor projects and expenditures against contract deliverables.

5a. Other Departments/Agencies:

Whatcom County agencies participating in FY20 OPSG in 2024 are: U.S. Border Patrol Blaine Sector and Whatcom County Sheriff's Office

Although receiving no OPSG funding, U.S. Border Patrol will provide coordination among participating agencies. Participating agencies receiving OPSG funding will provide enhanced law enforcement presence to reduce criminal activity in border areas.

5b. Name the person in charge of implementation and what they are responsible for:

6. Funding Source:

Indirect federal grant from Washington State Military Department. Funds originate from U.S. Department of Homeland Security (DHS) Homeland Security Grant Program (HSGP) FY20 OPSG Grant Program, CFDA No. 97.067.



STEELE INDUSTRIES INC

Unique Entity ID EWDNWFUJHBT1	CAGE / NCAGE 8DPM2	Purpose of Registration All Awards
Registration Status Active Registration	Expiration Date Oct 16, 2024	
Physical Address 10510 Portal Xing STE 101 Bradenton, Florida 34211-4911 United States	Mailing Address 10510 Portal Xing STE 101 Bradenton, Florida 34211-4911 United States	

Business Information

Doing Business as (blank)	Division Name (blank)	Division Number (blank)
Congressional District Florida 16	State / Country of Incorporation Florida / United States	URL (blank)

Registration Dates

Activation Date Nov 2, 2023	Submission Date Oct 17, 2023	Initial Registration Date Aug 26, 2019
---------------------------------------	--	--

Entity Dates

Entity Start Date Jul 19, 2019	Fiscal Year End Close Date Dec 31
--	---

Immediate Owner

CAGE (blank)	Legal Business Name (blank)
------------------------	---------------------------------------

Highest Level Owner

CAGE (blank)	Legal Business Name (blank)
------------------------	---------------------------------------

Executive Compensation

Registrants in the System for Award Management (SAM) respond to the Executive Compensation questions in accordance with Section 6202 of P.L. 110-252, amending the Federal Funding Accountability and Transparency Act (P.L. 109-282). This information is not displayed in SAM. It is sent to USAspending.gov for display in association with an eligible award. Maintaining an active registration in SAM demonstrates the registrant responded to the questions.

Proceedings Questions

Registrants in the System for Award Management (SAM.gov) respond to proceedings questions in accordance with FAR 52.209-7, FAR 52.209-9, or 2. C.F.R. 200 Appendix XII. Their responses are displayed in the responsibility/qualification section of SAM.gov. Maintaining an active registration in SAM.gov demonstrates the registrant responded to the proceedings questions.

Exclusion Summary

Active Exclusions Records?

No

SAM Search Authorization

I authorize my entity's non-sensitive information to be displayed in SAM public search results:

Yes

Entity Types

Business Types

Entity Structure Corporate Entity (Not Tax Exempt)	Entity Type Business or Organization	Organization Factors Subchapter S Corporation
Profit Structure For Profit Organization		

Socio-Economic Types

Check the registrant's Repts & Certs, if present, under FAR 52.212-3 or FAR 52.219-1 to determine if the entity is an SBA-certified HUBZone small business concern. Additional small business information may be found in the SBA's Dynamic Small Business Search if the entity completed the SBA supplemental pages during registration.

Financial Information

Accepts Credit Card Payments **Yes** Debt Subject To Offset **No**

EFT Indicator **0000** CAGE Code **8DPM2**

Points of Contact

Electronic Business

☒ **Dominick Steele** **10510 Portal Crossing Unit 101**
Bradenton, Florida 34211
United States

Government Business

☒ **Dominick Steele** **10510 Portal Crossing Unit 101**
Bradenton, Florida 34211
United States

Service Classifications

NAICS Codes

Primary **Yes** NAICS Codes **334511** NAICS Title **Search, Detection, Navigation, Guidance, Aeronautical, And Nautical System And Instrument Manufacturing**

Product and Service Codes

PSC **5855** PSC Name **Night Vision Equipment, Emitted And Reflected Radiation**

Disaster Response

Yes, this entity appears in the disaster response registry.
No, this entity does not require bonding to bid on contracts.

Bonding Levels	Dollars
	(blank)

States **Any** Counties **(blank)** Metropolitan Statistical Areas **(blank)**